

# Capri Multi



**+Halle®**

## Capri Multi

The Capri Multi offers a perfect combination of aesthetics and functionality. Its very wide seat allows room for the user and enables the possibility to change positions. As the name suggests, Capri Multi is designed for a great variety of spaces, such as break out areas, small meeting areas and waiting areas. The chromed steel legs and the upholstered shell in high quality molded foam makes Capri Multi a durable and distinct solution for all kinds of public spaces.

### Designed by busk+hertzog

The Danish design duo was established in 2000 with a clear vision of being innovative and professional - but also with the aim of leading and inspiring a new generation of designers to further develop the Danish design legacy.



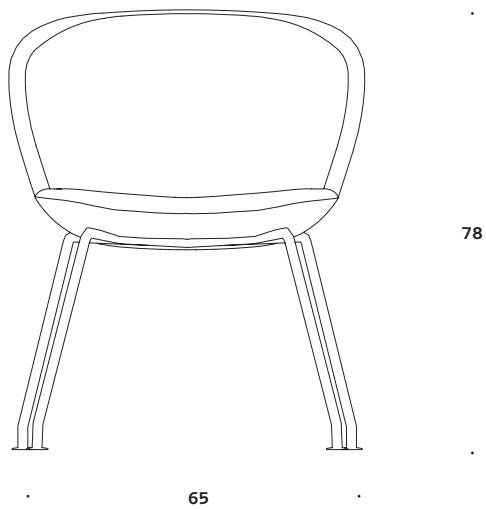
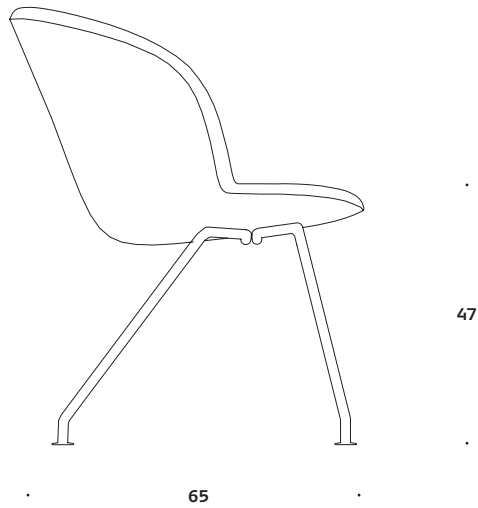

Dimensions defined in centimeters

---

**Design**

busk+hertzog

**Materials**

High quality moulded foam. Legs in chromed steel

**Fabric**

Available in a range of various fabrics and leather types

## Notes

A large grid of small dots for taking notes.

## Creating human spaces

**+Halle is a Danish high quality design furniture brand. We strive to add value to public areas by contributing to the creation of Human Spaces. The basic idea behind +Halle can be put down to a basic understanding of people.**